

CL31 Series Regulator

Commercial Regulator

The CL31 regulator can produce substantial savings for users in lower initial costs, lower installation costs and lower maintenance costs. Optimum valve design limits over boosting or rapid drop-off as the capacity requirement changes, including fast on-off loads.

The CL31 was designed for systems requiring highly accurate pressure regulation such as:

- » Utility “Fixed Factor” metering of relatively small loads (up to 4000 scfh)
- » Industrial Heating equipment requiring constant high burner pressures (1 psig to 20 psig)

DESCRIPTIONS

CL31N

The CL31N is a constant pressure loaded regulator that utilizes a pilot with no internal relief (N). This regulator can be used where psig to psig regulation is required with no internal relief.

CL31R

The CL31R is a constant pressure loaded regulator equipped with a pilot internal relief valve. The pilot relief valve is not designed for “full capacity” relief, but rather to limit the loading chamber pressure to a safe value in the event of failure.

CL-31IMR

The CL31IMR provides the same features as the ‘R’ model with token pilot relief valve backup of the monitor orifice if both the primary seat and monitor seat fail simultaneously.

CL-31IMRV

Operation is identical to the ‘IMR’ except that at no flow position of the monitor orifice a small volume of gas is vented through the relief valve to serve as a signal that the regulator is on monitor operation and the primary seat has failed. No gas is vented until the gas load is less than the volume going through the orifice vent hole and the regulator is on monitor operation.

- » Controlled size pilot breather orifice eliminates pulsation and provides normal breathing operation
- » “Stop stem” in pilot insures token internal relief valve operation
- » No special start-up procedures

FEATURES

- » Constant pressure loading provides “Fixed Factor” Measurement Accuracy Internal Bleed
- » Light closing spring for low lock-up
- » Wide outlet pressure range (1 psig to 20 psig)
- » One adjustable outlet spring (N version only)
- » Built in strainer screen in pilot regulator (N version only)
- » Extremely light weight
- » Compact design
- » Safety advantage of second gas tight lock-up seat with IM Version

CL31 SERIES COMMERCIAL REGULATOR

Shipping weight

Four regulators per box Box weight: 38 lbs.

CL31 DIMENSIONS (INCHES)

| Valve Body | A | B | C | D | E | F | G | H | J |
|------------|-------|-------|---|-------|---|---------|---------|----|---|
| 3/4 & 1 | 3-3/4 | 2-1/8 | 8 | 6-1/2 | 2 | 7-13/16 | 5-13/16 | 13 | 3 |
| 1-1/4 | 4 | 2-1/8 | | | | | | | |

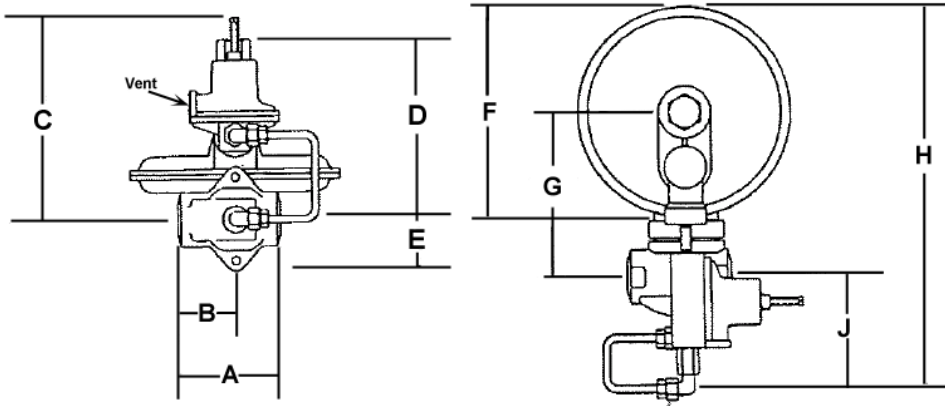

OPERATIONAL SCHEMATIC

Shown with N-type pilot

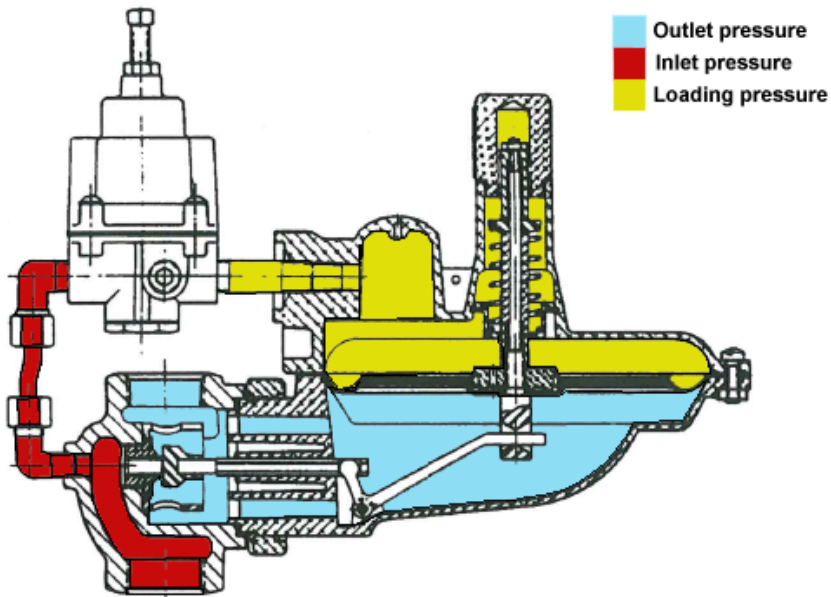

Note: valve shown in closed position.

SPRING DATA, SPRING COLOR OUTLET PRESSURE RANGE*

Spring Data, Spring Color Outlet Pressure Range*

| Models CL31R, CL31MR, CL31IMRV | PSIG |
|--------------------------------|-------------|
| Orange | 1.0 to 1.6 |
| Brown | 1.6 to 2.6 |
| Green | 3.5 to 7.4 |
| Black | 3.8 to 13.3 |
| Blue | 4.6 to 21.5 |
| Model CL31N | |
| Blue | 1 to 20 |

*WARNING Pilot springs are not interchangeable between N and R pilots.

ORIFICE DATA, WIDE OPEN FLOW COEFFICIENTS AND MAXIMUM PRESSURES

| Orifice Size (inches) | K-Factor | Maximum Operating Inlet Pressure (PSIG) | Maximum Emergency Inlet Pressure (PSIG) | Maximum Emergency Outlet Pressure (PSIG) |
|-----------------------|----------|---|---|--|
| 1/8 | 35 | 125 | 175 | |
| 1/8 IM | 30 | 125 | 175 | |
| 3/16 | 75 | 125 | 175 | |
| 3/16 IM | 75 | 125 | 175 | 60 |
| 1/4 | 127 | 125 | 175 | |
| 1/4 IM | 120 | 125 | 175 | |
| 3/8 | 290 | 60 | 90 | |
| 5/16 IM | 150 | 60 | 90 | |

OPERATING TEMPERATURE RANGE

- 20°F to 150°F

ADDITIONAL SPECIFICATIONS

| | |
|----------------------------|--|
| Available Pilot Vent Sizes | 1/4" NPT |
| Loading Ring Position | 0 degrees |
| Closing Spring (non-adj.) | Light green only |
| Other Available Options | Seal wire to indicate unapproved tampering |
| | 1/8" pipe plug tap on upstream side of valve body |
| | Pilot supply line filter (contact Itron, Liberty Lake, WA) |
| | Stainless steel supply line fittings |
| | Teflon valve body gasket |

CONSTRUCTION

Itron takes pride in delivering products with the utmost concern for safety, quality, and customer satisfaction.

Construction Materials

| | |
|-----------------------|---|
| Closing spring | Music wire |
| Valve body | High tensile strength cast iron (ASTM A-126, Class A) |
| Orifice | Brass (ASTM B16, Alloy 360), aluminum - optional |
| Valve seat | Buna-N or silicone (for temperatures below -20°F) |
| Valve stem | Plated steel (Aluminum alloy 2011-T3) |
| Lever pin | Stainless steel (Type 303) |
| Lever | Zinc and dichromate plated steel (AISI C1010) |
| Upper diaphragm plate | Zinc and dichromate plated steel (14 gauge steel) |
| Lower diaphragm plate | Die cast aluminum (ASTM B-85 Alloy SC84A) |
| Diaphragm | Buna-N and nylon |
| Pilot vent screen | Stainless steel (16 mesh) |
| Adjustment ferrule | Die cast aluminum (ASTM CS43A) |
| Seal cap | Die cast aluminum (ASTM CS43A) |
| Diaphragm case | Die cast aluminum (ASTM B85-Alloy SC84A) |

VALVE BODY SIZES (INCHES AND NPT THREAD TYPE)

| Inlet | Outlet |
|-------|--------|
| 3/4 | 3/4 |
| 3/4 | 1 |
| 3/4 | 1-1/4 |
| 1 | 1 |
| 1 | 1-1/4 |
| 1-1/4 | 1-1/4 |

CORRECTION FACTORS FOR NON-NATURAL GAS APPLICATIONS

The CL31 may be used to control gases other than natural gas. To determine the capacity for gases other than natural gas, multiply the values within the capacity tables by a correction factor. The table below lists the correction factors for some of the more common gases:

| Gas Type | Specific Gravity | Correction Factor (CF) |
|-----------------------|------------------|------------------------|
| Air | 1.00 | 0.77 |
| Butane | 2.01 | 0.55 |
| Carbon Dioxide (Dry) | 1.52 | 0.63 |
| Carbon Monoxide (Dry) | 0.97 | 0.79 |
| Natural Gas | 0.60 | 1.00 |
| Nitrogen | 0.97 | 0.79 |
| Propane | 1.53 | 0.63 |
| Propane-Air-Mix | 1.20 | 0.71 |

To calculate the correction factor for gases not listed in the table above, use the gases' specific gravity and insert it in the formula listed below:

$$\text{Correction Factor (CF)} = \sqrt{\frac{SG_1}{SG_2}}$$

Where:

SG₁ = Specific gravity of the gas in which the capacity is published.

SG₂ = Specific gravity of the gas to be controlled.

Wide Open Flow Calculations

For wide-open orifice flow calculations use the following equations:

$$\text{For } \frac{P_1}{P_2} < 1.89 \quad \text{use: } Q = K\sqrt{P_2(P_1 - P_2)}$$

$$\text{For } \frac{P_1}{P_2} > 1.89 \quad \text{use: } Q = \frac{KP_1}{2}$$

Where: P₁ = Absolute Inlet Pressure (PSIA)

P₂ = Absolute Outlet Pressure (PSIA)

Q = Flow Rate (SCFH)

K = Orifice Coefficient (SCFH/PSI)

CL31 SERIES COMMERCIAL REGULATOR, MODELS N AND R

Capacity Table (1% Absolute Droop*)

Capacities in SCFH of 0.6 S.G. gas; base conditions of 14.7 PSIA and 60° F.

| Typical Capacity Info. | |
|------------------------|--------|
| Manufacturer | Itron |
| Type and model | CL31 |
| Regulator | |
| Inlet size | 1-1/4" |
| Outlet size | 1-1/4" |
| Spring color | Varies |
| Position | 5 |

| Inlet Pressure (PSIG) | Outlet Pressure (PSIG) | Orifice Size | | | |
|-----------------------|------------------------|--------------|-------|------|------|
| | | 1/8" | 3/16" | 1/4" | 3/8" |
| 2 | 1 | | 300 | 300 | 500 |
| | 3 | | | | |
| 3 | 1 | | 400 | 500 | 905 |
| | 2 | | 325 | 350 | 1650 |
| 5 | 1 | 325 | 550 | 850 | 1650 |
| | 2 | 275 | 500 | 800 | 1450 |
| 10 | 1 | 400 | 825 | 1450 | 2550 |
| | 2 | 400 | 825 | 1450 | 2550 |
| | 5 | 400 | 625 | 1050 | 1700 |
| 15 | 1 | 500 | 1025 | 1750 | 3300 |
| | 2 | 500 | 1025 | 1750 | 3300 |
| | 5 | 500 | 1025 | 1700 | 2750 |
| | 10 | 400 | 700 | 1000 | 1700 |
| 20 | 1 | 575 | 1275 | 2100 | 3700 |
| | 2 | 575 | 1275 | 2100 | 3700 |
| | 5 | 575 | 1200 | 2100 | 3500 |
| | 10 | 500 | 1075 | 1750 | 3000 |
| | 15 | 400 | 825 | 800 | 1700 |
| 30 | 1 | 700 | 1600 | 2800 | 4000 |
| | 2 | 700 | 1600 | 2800 | 4000 |
| | 5 | 700 | 1600 | 2800 | 4000 |
| | 10 | 700 | 1600 | 2800 | 4000 |
| | 15 | 700 | 1450 | 2100 | 4000 |
| | 20 | 575 | 1200 | 1900 | 3200 |
| 40 | 1 | 900 | 1975 | 3400 | 4000 |
| | 2 | 900 | 1975 | 3400 | 4000 |
| | 5 | 900 | 1975 | 3400 | 4000 |
| | 10 | 900 | 1975 | 3400 | 4000 |
| | 15 | 900 | 1975 | 3300 | 4000 |
| | 20 | 900 | 1850 | 3300 | 4000 |
| 50 | 1 | 1075 | 2350 | 4000 | 4000 |
| | 2 | 1075 | 2350 | 4000 | 4000 |
| | 5 | 1075 | 2350 | 4000 | 4000 |
| | 10 | 1075 | 2350 | 4000 | 4000 |
| | 15 | 1075 | 2350 | 4000 | 4000 |
| | 20 | 1075 | 2350 | 4000 | 4000 |

Notes:

3/4-inch outlet pipe size limits the capacity to 2000 SCFH.

1-inch outlet pipe size limits to 3000 SCFH.

*Individual regulator performance may vary from data shown.

■ Inlet pressure is too low to achieve desired outlet pressure.

CL31 SERIES COMMERCIAL REGULATOR, MODELS N AND R (CONTINUED)

Capacity Table (1% Absolute Droop*)

Capacities in SCFH of 0.6 S.G. gas; base conditions of 14.7 PSIA and 60° F.

| Typical Capacity Info. | |
|------------------------|--------|
| Manufacturer | Itron |
| Type and model | CL31 |
| Regulator | |
| Inlet size | 1-1/4" |
| Outlet size | 1-1/4" |
| Spring color | Varies |
| Position | 5 |

| Inlet Pressure (PSIG) | Outlet Pressure (PSIG) | Orifice Size | | | |
|-----------------------|------------------------|--------------|-------|------|------|
| | | 1/8" | 3/16" | 1/4" | 3/8" |
| 60 | 1 | 1200 | 2675 | 4000 | 4000 |
| | 2 | 1200 | 2675 | 4000 | 4000 |
| | 5 | 1200 | 2675 | 4000 | 4000 |
| | 10 | 1200 | 2675 | 4000 | 4000 |
| | 15 | 1200 | 2675 | 4000 | 4000 |
| | 20 | 1200 | 2675 | 4000 | 4000 |
| 75 | 1 | 1400 | 3150 | 4000 | |
| | 2 | 1400 | 3150 | 4000 | |
| | 5 | 1400 | 3150 | 4000 | |
| | 10 | 1400 | 3150 | 4000 | |
| | 15 | 1400 | 3150 | 4000 | |
| | 20 | 1400 | 3150 | 4000 | |
| 100 | 1 | 1700 | 4000 | 4000 | |
| | 2 | 1700 | 4000 | 4000 | |
| | 5 | 1700 | 4000 | 4000 | |
| | 10 | 1700 | 4000 | 4000 | |
| | 15 | 1700 | 4000 | 4000 | |
| | 20 | 1700 | 4000 | 4000 | |
| 125 | 1 | 2100 | 4000 | 4000 | |
| | 2 | 2100 | 4000 | 4000 | |
| | 5 | 2100 | 4000 | 4000 | |
| | 10 | 2100 | 4000 | 4000 | |
| | 15 | 2100 | 4000 | 4000 | |
| | 20 | 2100 | 4000 | 4000 | |

Notes:

3/4-inch outlet pipe size limits the capacity to 2000 SCFH.

1-inch outlet pipe size limits to 3000 SCFH.

*Individual regulator performance may vary from data shown.

Do not operate orifice in shaded inlet pressure area.

CL31 PERFORMANCE CURVES

5, 10 PSIG Set Point

Type and model CL31R

Inlet size 1 1/4-inch NPT

Outlet size 1 1/4-inch NPT

Orifice size 1/4-inch

Set point 5 PSIG with 40 PSIG inlet @ 200 SCFH. All test results are reported at a base of 14.7 PSIG at 60° F and with 0.6 S.G. gas.

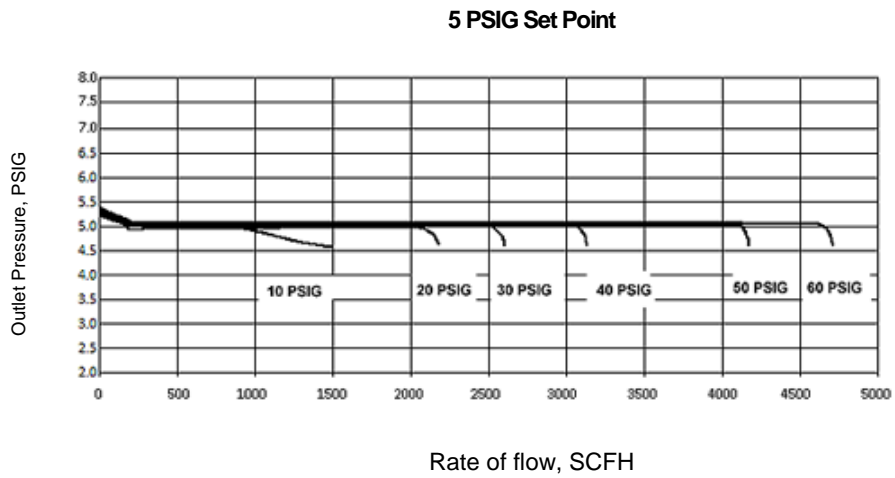

5, 10 PSIG Set Point

Type and model CL31R

Inlet size 1 1/4-inch NPT

Outlet size 1 1/4-inch NPT

Orifice size 1/4-inch

Set point 10 PSIG with 40 PSIG inlet @ 200 SCFH. All test results are reported at a base of 14.7 PSIG at 60° F and with 0.6 S.G. gas.

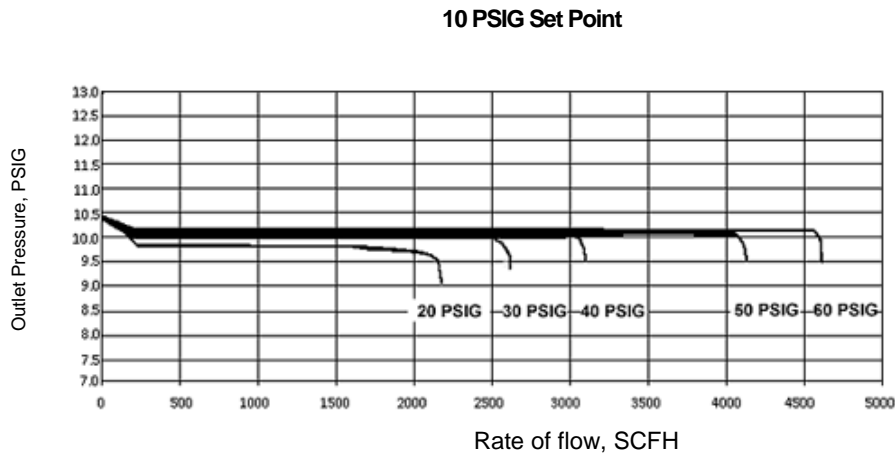

CL31 IM INTERNAL MONITOR* SERVICE REGULATOR

General Description

The CL31 IM regulator is designed specifically to comply with BOT OPS 192.197, paragraph B which states, "or if the gas contains materials that seriously interfere with the operation of a service regulator, there must be suitable protective devices to prevent unsafe over-pressuring of the customer's appliance, if the service regulator fails." The code lists the devices, one of which is the regulator and monitor. The code further states these devices may be installed as an internal part of the service regulator or as a separate unit. The internal monitor (IM) is a single valve body regulator with built-in monitor operation. It features the safety advantage of a second gas tight lock-up seat if the normal orifice face and valve seat fail to product the adjusted outlet pressure. The monitor also controls gas flow between the failed open flow and no flow; providing complete secondary regulation and monitor regulation function without relieving gas to the atmosphere or shutting off the gas flow to the customer. The monitor overpressure takeover is a 0.5 PSIG increase on regulators set for 2 PSIG and 1 PSIG increase on regulators set for 5 PSIG.

*Patent numbers 3,613,725 and 3,751,570.

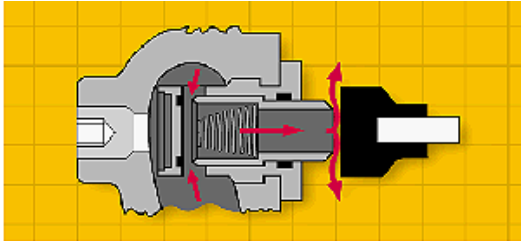

A. Standard regulator and upstream monitor orifice.

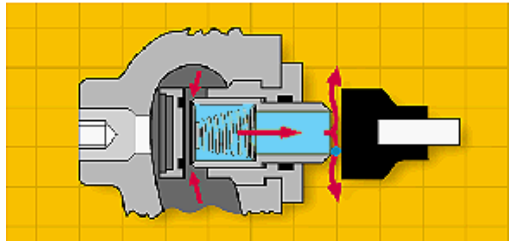

B. Standard regulator orifice failed; upstream monitor orifice control.

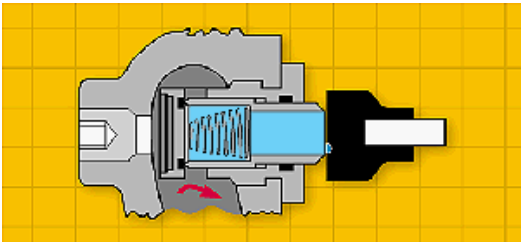

C. Main orifice failed - upstream monitor orifice *lock-up*.

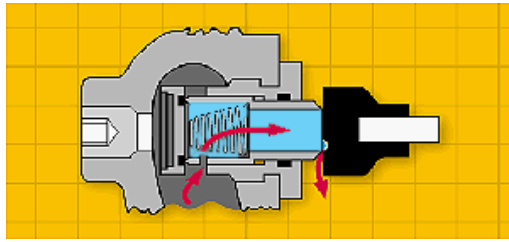

D. V option - vents a small volume of gas to atmosphere through relief valve.

 Inlet pressure  Outlet pressure

PRINCIPLE OF OPERATION

A. Normal operation. The internal monitor IM orifice performs like a standard regulator and monitor regulator in that main orifice and valve seat actuate to control outlet flow and pressure under normal flow conditions. If there is no demand, the main seat *and internal monitor orifice will close*.

B. Monitor operation. If the main valve seat fails to control the gas flow and pressure due to foreign matter between the seat and orifice face, or if the seat is eroded, the internal monitor orifice automatically goes into operating position at a slightly higher outlet pressure (see Internal Monitor Lock-up Pressure table). Any time the pressure on the main diaphragm exceeds the force of the fixed monitor spring, the increased outlet pressure causes the main valve seat to push against the sliding orifice. The sliding orifice compresses the monitor spring and positions the monitor orifice to control the gas flow. The IM orifice now functions as a monitor regulator and continues to monitor as long as the main seat fails to control at the normal adjusted outlet pressure. If the gas load demand is increased beyond the internal monitor's capacity, the outlet pressure is reduced to normal adjusted pressure and the regulator resumes normal regulation.

C. Monitor lock-up. If the demand for gas is decreased to zero flow during monitor operation, the sliding orifice continues to close until its orifice is in the gas tight position (monitor lock-up) against the BUNA-N monitor valve seat. (See the Internal Monitor Lock-up Pressure table for the outlet pressure required for internal monitor lock-up.)

D. Vent hole V option. On installations where a small volume of over-pressure gas can be safely vented to the atmosphere, the advantages of both the pilot relief valve and monitor safety can be combined. If the flow is decreased to zero or just greater than zero, the vent hole in the internal monitor orifice allows gas to slowly bleed downstream and cause the pressure to rise to the relief point of the pilot's internal relief valve. The gas then bleeds to the atmosphere indicating a problem with the regulator.

INTERNAL MONITOR LOCK-UP PRESSURE

| Outlet pressure set point (PSIG) | Pilot spring | IM lock-up pressure (PSIG) |
|----------------------------------|--------------|----------------------------|
| 1 | Orange | 1.5 |
| 2 | Brown | 2.5 |
| 5 | Green | 5.6 |
| 10 | Black | 10.8 |
| 15 | Blue | 16.2 |
| 20 | Blue | 21.2 |

Note The above tests were conducted using a 0.1-inch diameter nylon rod glued to the valve seat.

CL31 SERIES COMMERCIAL REGULATOR, MODELS IMR AND IMRV

Note Internal Monitor is not available on CL31N model.

Capacity Table (1% Absolute Droop*)

Capacities in SCFH of 0.6 S.G. gas; base conditions of 14.7 PSIA and 60° F.

Typical Capacity Info.

| | |
|---------------------|---------|
| Manufacturer | Itron |
| Type and model | CL31 IM |
| Regulator | |
| Inlet size | 1-1/4" |
| Outlet size | 1-1/4" |
| Spring color | Varies |
| Position | 5 |

| Inlet Pressure (PSIG) | Outlet Pressure (PSIG) | Orifice Size | | | |
|-----------------------|------------------------|--------------|-------|------|-------|
| | | 1/8" | 3/16" | 1/4" | 5/16" |
| 2 | 1 | | 300 | 300 | 300 |
| 3 | 1 | | 400 | 475 | 500 |
| | 2 | | 300 | 325 | 350 |
| 5 | 1 | 325 | 550 | 675 | 850 |
| | 2 | 275 | 500 | 600 | 680 |
| 10 | 1 | 400 | 825 | 1050 | 1250 |
| | 2 | 400 | 825 | 1025 | 1250 |
| | 5 | 400 | 625 | 850 | 1000 |
| 15 | 1 | 500 | 1025 | 1400 | 1650 |
| | 2 | 500 | 1025 | 1375 | 1650 |
| | 5 | 500 | 950 | 1275 | 1525 |
| | 10 | 400 | 625 | 900 | 1050 |
| 20 | 1 | 575 | 1200 | 1700 | 2000 |
| | 2 | 575 | 1200 | 1700 | 2000 |
| | 5 | 575 | 1200 | 1625 | 2000 |
| | 10 | 500 | 1050 | 1200 | 1725 |
| | 15 | 400 | 750 | 900 | 1250 |
| 30 | 1 | 700 | 1575 | 2275 | 2700 |
| | 2 | 700 | 1575 | 2275 | 2700 |
| | 5 | 700 | 1575 | 2250 | 2700 |
| | 10 | 700 | 1575 | 2050 | 2550 |
| | 15 | 700 | 1450 | 1900 | 2275 |
| | 20 | 575 | 1200 | 1625 | 1950 |
| 40 | 1 | 900 | 1900 | 2850 | 3300 |
| | 2 | 900 | 1900 | 2850 | 3300 |
| | 5 | 900 | 1900 | 2850 | 3300 |
| | 10 | 900 | 1900 | 2750 | 3300 |
| | 15 | 900 | 1900 | 2575 | 3100 |
| | 20 | 900 | 1775 | 2500 | 3000 |
| 50 | 1 | 1075 | 2250 | 3400 | 4000 |
| | 2 | 1075 | 2250 | 3400 | 4000 |
| | 5 | 1075 | 2250 | 3400 | 4000 |
| | 10 | 1075 | 2250 | 3300 | 4000 |
| | 15 | 1075 | 2250 | 3250 | 4000 |
| | 20 | 1075 | 2200 | 3175 | 4000 |

Notes

3/4-inch outlet pipe size limits the capacity to 2000 SCFH.

1-inch outlet pipe size limits the capacity to 3000 SCFH.

*Individual regulator performance may vary from data shown.

■ Inlet pressure is too low to achieve desired outlet pressure.

CL31 SERIES COMMERCIAL REGULATOR, MODELS IMR AND IMRV (CONTINUED)

Note Internal Monitor is not available of CL31N model.

Capacity Table (1% Absolute Droop*)

Capacities in SCFH of 0.6 S.G. gas; base conditions of 14.7 PSIA and 60° F.

| Inlet Pressure (PSIG) | | Outlet Pressure (PSIG) | Orifice Size | | | |
|-------------------------------|-----------------------|------------------------|--------------|-------|------|-------|
| | | | 1/8" | 3/16" | 1/4" | 5/16" |
| Typical Capacity Info. | Manufacturer | Itron | | | | |
| | Type and model | CL31 IM | | | | |
| | Regulator | | | | | |
| | Inlet size | 1-1/4" | | | | |
| | Outlet size | 1-1/4" | | | | |
| | Spring color | Varies | | | | |
| Position | 5 | | | | | |
| 60 | 1 | 1200 | 2575 | 3900 | 4000 | |
| | 2 | 1200 | 2575 | 3900 | 4000 | |
| | 5 | 1200 | 2575 | 3900 | 4000 | |
| | 10 | 1200 | 2575 | 3900 | 4000 | |
| | 15 | 1200 | 2575 | 3900 | 4000 | |
| | 20 | 1200 | 2575 | 3900 | 4000 | |
| 75 | 1 | 1400 | 3075 | 4000 | 4000 | |
| | 2 | 1400 | 3075 | 4000 | 4000 | |
| | 5 | 1400 | 3075 | 4000 | 4000 | |
| | 10 | 1400 | 3075 | 4000 | 4000 | |
| | 15 | 1400 | 3075 | 4000 | 4000 | |
| | 20 | 1400 | 3075 | 4000 | 4000 | |
| 100 | 1 | 1700 | 3600 | 4000 | 4000 | |
| | 2 | 1700 | 3600 | 4000 | 4000 | |
| | 5 | 1700 | 3600 | 4000 | 4000 | |
| | 10 | 1700 | 3600 | 4000 | 4000 | |
| | 15 | 1700 | 3600 | 4000 | 4000 | |
| | 20 | 1700 | 3600 | 4000 | 4000 | |
| 125 | 1 | 2100 | 4000 | 4000 | 4000 | |
| | 2 | 2100 | 4000 | 4000 | 4000 | |
| | 5 | 2100 | 4000 | 4000 | 4000 | |
| | 10 | 2100 | 4000 | 4000 | 4000 | |
| | 15 | 2100 | 4000 | 4000 | 4000 | |
| | 20 | 2100 | 4000 | 4000 | 4000 | |

Notes

3/4-inch outlet pipe size limits the capacity to 2000 SCFH.

1-inch outlet pipe size limits the capacity to 3000 SCFH.

*Individual regulator performance may vary from data shown.

Do not operate orifice in shaded inlet pressure area.

ASSEMBLY POSITIONS

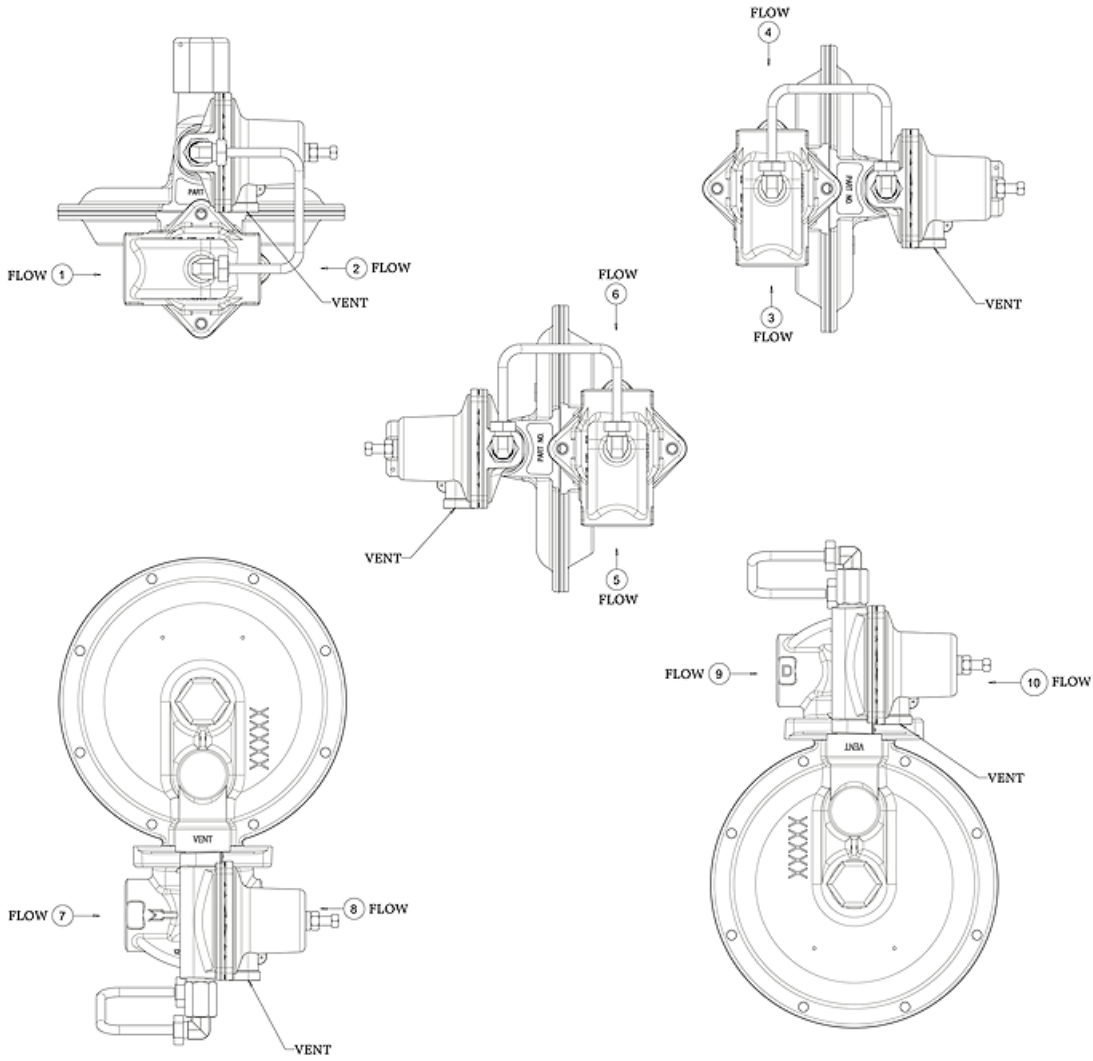

CL31 SERIES REGULATORS, R AND N MODELS

CL31 R

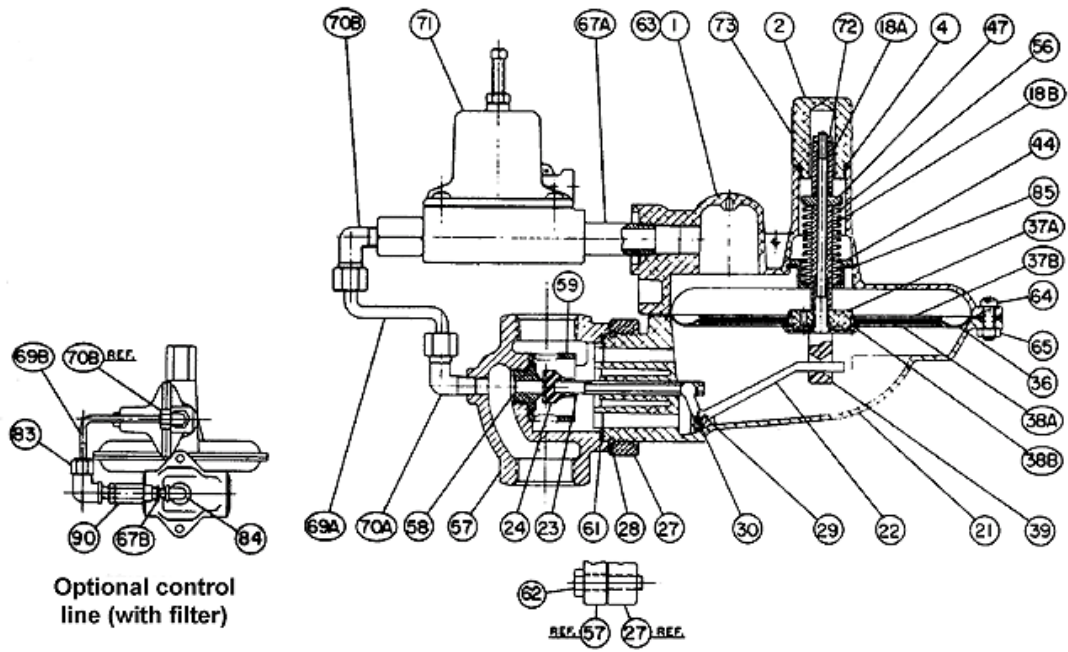

CL31 N

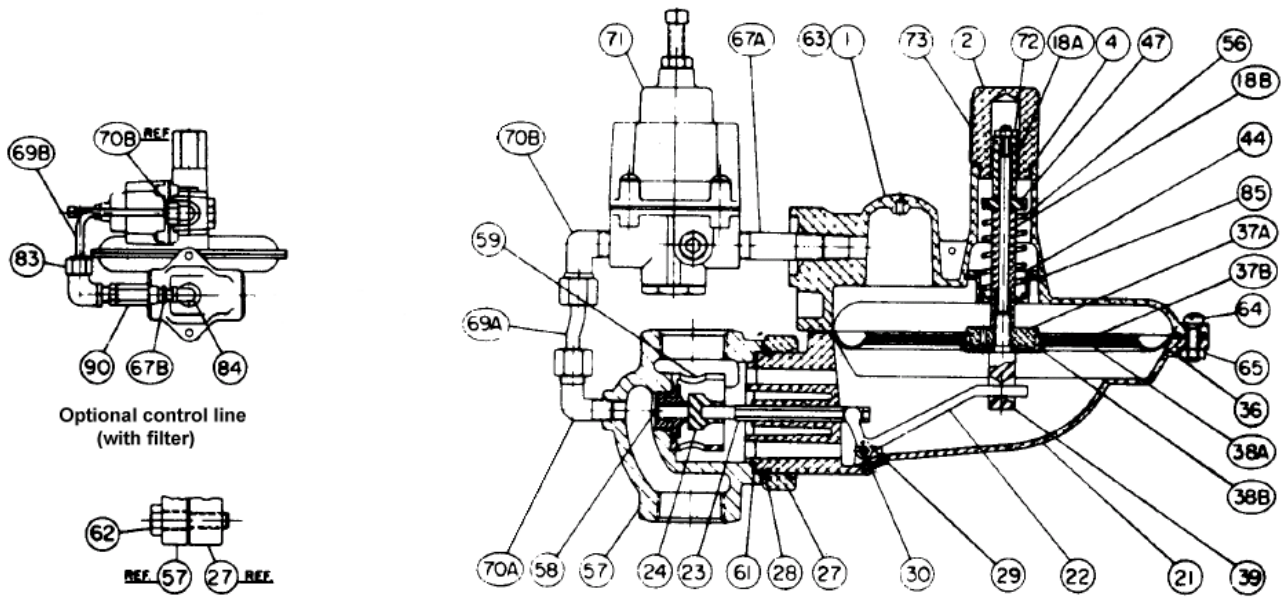

PARTS LIST

| Item No. | Part No. | Quantity Required per Regulator Model | | Description |
|----------|------------|---------------------------------------|---|--|
| | | N | R | |
| 1 | 753194 | 1 | | Upper diaphragm case, vent 1/4" pipe |
| | 753199 | | 1 | Upper diaphragm case, vent 3/8" pipe |
| 2 | | 1 | 1 | Seal cap, please specify |
| | 760001 | | | With seal wire hole |
| | 760011 | | | Without seal wire hole |
| | 760013 | | | With seal wire hole |
| 4 | 765503 | 1 | 1 | Seal cap gasket |
| 18A | 754721 | 1 | 1 | Stop stem spacer, upper |
| 18B | 754725 | 1 | 1 | Stop stem spacer, lower |
| 21 | 752124 | 1 | 1 | Lower diaphragm case, 4:1 lever ratio |
| 22 | 761231 | 1 | 1 | Valve linkage lever, 4:1 lever ratio |
| 23 | 754021 | 1 | 1 | Valve stem |
| 24 | 765027 | 1 | 1 | Valve seat, Buna N, standard |
| 27 | 751913 | 1 | 1 | Valve body retainer plate, aluminum |
| 28 | 755725 | 1 | 1 | Retainer plate snap ring |
| 29 | 755141 | 2 | 2 | Valve linkage pin screw |
| 30 | 754831 | 1 | 1 | Valve linkage pin |
| 36 | 766121 | 1 | 1 | Diaphragm |
| 37A | 761031 | 1 | 1 | Upper diaphragm plate |
| 37B | 761025 | 1 | 1 | Upper diaphragm plate, steel |
| 38A | 761025 | 1 | 1 | Lower diaphragm plate, steel |
| 38B | 756091 | 1 | 1 | Lower diaphragm plate |
| 39 | 754331 | 1 | 1 | Stop stem |
| 44 | 754901 | 1 | 1 | Stop stem guide bushing |
| 47 | 761495 | 1 | 1 | Closing spring guide |
| 56 | 762119 | 1 | 1 | Closing spring, light green |
| 57 | | 1 | 1 | Valve bodies. Straight. Please specify size |
| | 750060 | | | 3/4" x 3/4" NPT with 1/8" NPT |
| | 750069 | | | 3/4" x 1" NPT with 1/8" NPT |
| | 750078 | | | 1" x 1" NPT with 1/8" NPT |
| | 750110 | | | 3/4" x 1-1/4" NPT with 1/8" NPT |
| | 750119 | | | 1" x 1-1/4" NPT with 1/8" NPT |
| | 750134 | | | 1-1/4" x 1-1/4" NPT with 1/8" NPT |
| | | | | |
| 58 | | 1 | 1 | Orifice, brass. Please specify size. |
| | 757255 | | | 1/8" Diameter |
| | 757259 | | | 3/16" Diameter |
| | 757263 | | | 1/4" Diameter |
| | 757271 | | | 3/8" Diameter |
| 59 | 761753 | 1 | 1 | Loading ring |
| 61 | 765753 | 1 | 1 | Valve body gasket |
| 62 | 755386 | 2 | 2 | Retainer plate screw, hex head, 5/16", 18 x 1-1/4" Lg. |
| 63 | 769151 | 1 | 1 | Curved regulator plate |
| 64 | 755304-001 | 8 | 8 | Case screw, hex head, 1/4", 20 x 3/4" |
| 65 | 755513-001 | 8 | 8 | Case nut, hex head, 1/4", 20 |
| 67A | 768133 | | 1 | Nipple, 3/8" NPT x 2" |

| Item No. | Part No. | Quantity Required per Regulator Model | | Description |
|-------------------------------|------------|---------------------------------------|---|---|
| | | N | R | |
| | 768123 | 1 | | Nipple, 1/4" NPT x 2" |
| 67B | 768101 | 1 | 1 | Pipe nipple, male, 1/8" x 1/4" NPT steel |
| 69A | 768507 | 1 | 1 | Control line, 1/4" steel |
| 69B | 768541 | 1 | 1 | Control line, 1/4" D tube, steel |
| 70A | 768251 | 1 | 1 | 90° Male elbow, 1/4" tube x 1/8" NPTF, steel |
| 70B | 768257 | 1 | 1 | 90° Male elbow, 1/4" tube x 1/4" NPTF, steel |
| | | | | *Optional control line with filter assembly. Call Itron, Liberty Lake, WA |
| 71 | 700321 | 1 | | Pilot assembly, N version only, blue spring |
| | 762631 | | 1 | Orange, adjustment spring only |
| | 762633 | | 1 | Brown, adjustment spring only |
| | 762635 | | 1 | Green, adjustment spring only |
| | 762637 | | 1 | Black, adjustment spring only |
| | 762639 | | 1 | Blue, adjustment spring only |
| 72 | 755621 | 1 | 1 | Stop stem nut (Hex) #10-24 |
| 73 | 769401 | 1 | 1 | Warning sticker, seal cap |
| 83 | 768273 | 1 | 1 | 90° Female elbow, 1/4" tube x 1/4" NPT, steel |
| 84 | 768291 | 1 | 1 | 90° Street elbow, 1/4" NPT, steel |
| 85 | 755731 | 1 | 1 | Stem guide bushing retainer ring |
| 90 | 768481 | 1 | 1 | Control line filter |
| CL31 Repair Kit 770033 | | | | |
| | 765027 | 1 | | Valve seat 85 Duro IM (white stripe) |
| | 765503 | 1 | | Seal cap O-ring |
| | 765753 | 1 | | Valve body gasket pilot |
| | 766001 | 1 | | Diaphragm pilot |
| | 766130-001 | 1 | | Diaphragm with O-ring seal |

VENT LINES FOR REGULATORS

When constructing vent lines to be attached to regulators installed indoors, follow a few basic rules:

- a. Never use pipe sizes smaller than the vent size; smaller pipe sizes restrict the gas flow. If a long gas run must be used, Itron advises increasing the pipe one nominal size every ten feet to keep the flow restriction as low as possible.
- b. Keep the vent line length as short as possible to minimize the restriction and reduce the vent's tendency to cause regulator pulsation.
- c. Support the vent pipe to eliminate strain on the regulator diaphragm case.
- d. Always point outdoor vent pipes in the downward position to reduce the possibility of rain, snow, sleet, and other moisture entering the pipe. Install a bug screen in the end of the pipe.
- e. Do not locate the vent line terminus near windows, fans, or other ventilation equipment. See the installation instructions furnished with the regulator.
- f. Adhere to all applicable codes and regulations.
- g. If your vent pipe causes regulator pulsation, consult your sales representative or manufacturer.
- h. Itron strongly recommends running a separate vent line for each regulator. Headers with various installed devices can cause regulator malfunction.

Caution Ensure the end of the vent line is away from ANY potential ignition sources. It is the installer's responsibility to verify the vent line is exhausting to a safe environment.

INSTALLATION

Warning Itron does not endorse or warrant the completeness or accuracy of any third party regulator installation procedures or practices, unless otherwise provided in writing by Itron. Follow your company's standard operating procedures regarding the use of personal protection equipment (PPE). Adhere to guidelines issued by your company in addition to those given in this document when installing regulators.

- a. Remove all shipping plugs from the regulator inlet, outlet, and vent before installation.
- b. Verify the piping interior and regulator inlet and outlet are clean and free of dirt, pipe dope, and other debris. Dirt and other foreign materials entering the regulator can cause a loss of pressure control.
- c. Apply pipe joint sealant to the male pipe threads. Do not use pipe joint material on the regulator's female threads. Joint sealant could become lodged in the regulator and cause a loss of pressure control.
- d. Gas must flow through the regulator's valve body in the direction cast on the regulator body. Gas flowing in the wrong direction can overpressure and cause damage to the regulator.
- e. The pilot diaphragm casing can be mounted in any position relative to the body through a full 360° angle at 90° increments.
- f. When the regulator is installed OUTDOORS, the vent must always be positioned so that rain, snow, moisture or foreign particles cannot enter the vent opening. Itron recommends positioning the pilot vent downward to avoid entry of water or other matter which could interfere with the proper operation of the regulator. The vent should be located away from building eaves, window openings, building air intakes and above the expected snow level at the site. The vent opening should be inspected periodically to insure it does not become blocked by foreign material as outlined in DOT PHMSA-RSPA-2004-19856.
- g. When the regulator is installed INDOORS, the vent must be piped to the outside atmosphere using the shortest length of pipe, the fewest possible pipe elbows, and a pipe diameter as large as the vent size or larger. USING VENT PIPE SMALLER THAN THE VENT CONNECTION LIMITS THE REGULATOR'S INTERNAL RELIEF VALVE CAPACITY. The outlet end of the pipe must be protected from moisture and the entrance of foreign particles. The regulator should be specified by the user with the size vent and pipe threads desired to make the vent pipe connection.

START-UP PROCEDURE

- a. Mount a pressure gauge downstream of the regulator to monitor the downstream pressure.
- b. With the downstream pressure valve closed, slowly open the inlet valve. The outlet pressure should rise to slightly more than the set-point. Verify there are no leaks and all connections are tight.
- c. The regulator was pre-set at the factory to match order specifications. If necessary, adjust the outlet pressure by removing the seal cap on the top of the pilot spring housing and adjusting the screw on the top of the pilot spring housing using a wrench. Do not remove the seal cap from the main regulator unless all of the gas is shut off and all of the pressure is released from the regulator. Failure to shut off gas and release pressure from the regulator will allow pressurized gas to escape from the regulator. With a small amount of gas flowing through the regulator, rotate the pilot screw clockwise to raise the outlet pressure or counter-clockwise to lower the outlet pressure.
- d. Replace the seal cap and check for leaks after the desired outlet pressure is achieved.

The regulator is ready for operation.

SAFETY WARNING

This product, as of the date of manufacture, is designed and tested to conform to all governmental and industry safety standards as they may apply to the manufacturer. The purchaser/user of this product must comply with all fire control, building codes, and other safety regulations governing the application, installation, operation, and general use of this regulator to avoid leaking gas hazards resulting from improper installation, startup or use of this product.

Itron strongly recommends installation by a qualified professional and periodic inspection of pressure regulators (inspections may be required by local applicable codes or regulations).

Inspections should include checking for gas quality, cycle numbers, external environmental changes, and operating conditions that impact wear on the regulator's moving parts. To ensure safe and efficient operation of this product, replace worn or damaged parts found during inspection.

LIMITED WARRANTY

Itron, Inc. 2111 North Molter Road Liberty Lake, WA 99019, warrants this gas product against defects in materials and workmanship for the earlier of one (1) year from the date the product is shipped by Itron or a period of one year from the date the product is installed by Itron at the original purchaser's site. During such one-year period, provided that the original purchaser continues to own the product, Itron will, at its sole option, repair any defects, replace the product or repay the purchase price.

» This warranty will be void if the purchaser fails to observe the procedures for installation, operation or service of the product as set forth in the Operating Manual and Specifications for the product or if the defect is caused by tampering, physical abuse or misuse of the product.

» Itron specifically disclaims all implied warranties including those of merchantability or of fitness for particular purpose. Under no circumstances will Itron be liable for incidental or consequential damages of any kind whatsoever.

» Itron's liability for any claim of any kind, including negligence and breach of warranty for the sale and use of any product covered by or furnished, shall in no case exceed the price allocable to the product or part thereof which gives rise to the claim.

» In the event of a malfunction of the product, consult your Itron Service Representative or Itron Inc., 2111 North Molter Road Liberty Lake, WA 99019. See Itron Terms and Conditions of Sale for the full and complete terms of the Limited Warranty.

ORDERING INFORMATION

1. Inlet and outlet connection size and type
2. Model number
3. Outlet pressure desired
4. Inlet pressure range
5. Type of gas and maximum capacity required
6. Assembly position number (see diagram above)
7. Vent size
8. Special requirements such as tagging, pipe plug tap, seal wire, etc.



Join us in creating a more **resourceful world**.
To learn more visit **itron.com**

While Itron strives to make the content of its marketing materials as timely and accurate as possible, Itron makes no claims, promises, or guarantees about the accuracy, completeness, or adequacy of, and expressly disclaims liability for errors and omissions in, such materials. No warranty of any kind, implied, expressed, or statutory, including but not limited to the warranties of non-infringement of third party rights, title, merchantability, and fitness for a particular purpose, is given with respect to the content of these marketing materials. © Copyright 2018 Itron. All rights reserved. 101042SP-05 09/18

CORPORATE HQ

2111 North Molter Road
Liberty Lake, WA 99019 USA

Phone: 1.800.635.5461

Fax: 1.509.891.3355